

Segment: Non-Automobile Industry

Application: Palletizing System

Organization: Yaskawa India Pvt.Ltd.

Description:

Robotic Palletizing system for Non-Automobile Industries- The system is capable for handling pallet, slip sheet & placing bag as per user defined orientation.

Objective: Automated solution for palletizing bag with smart solution for palletizing sequence to achieve production volume, to improve quality, eliminate human error and reduce manual work.

System Overview:

Robot is integrated for pallet dispensing, slip sheet handling & palletizing bag using claw type bag gripper. Yaskawa Pallet solver software is used for the quick generation of placing sequence without any manual robot programming. Pallet solver is a PC based software which is used for the quick generation of placing sequence patterns. Robot gripper is designed to handle different model of bags. MPL160-II 4-Axis palletizing robot delivers high speed operation.

Scope of supply:

- Robot : MPL160-II
- Controller : DX200
- Robot option function: Pallet solver software
- PLC Communication: Ethernet TCP/IP
- Gripper : Pneumatic & Vacuum Operated
- No. of variants : 05
- No. of infeed station : 01
- No. of Placing station : 01
- No: of slip-sheet station: 01

Application Layout:

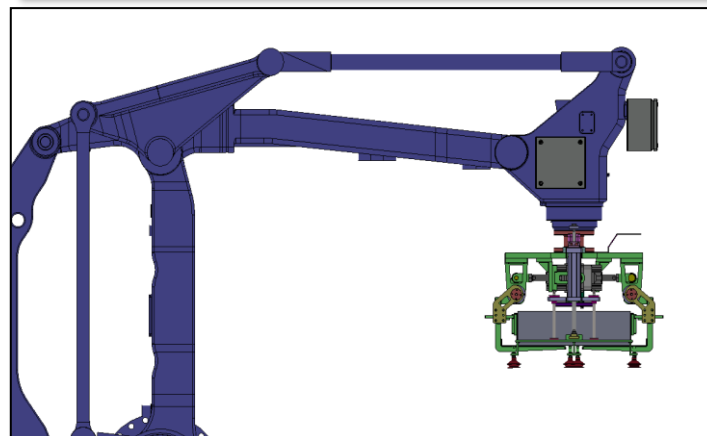
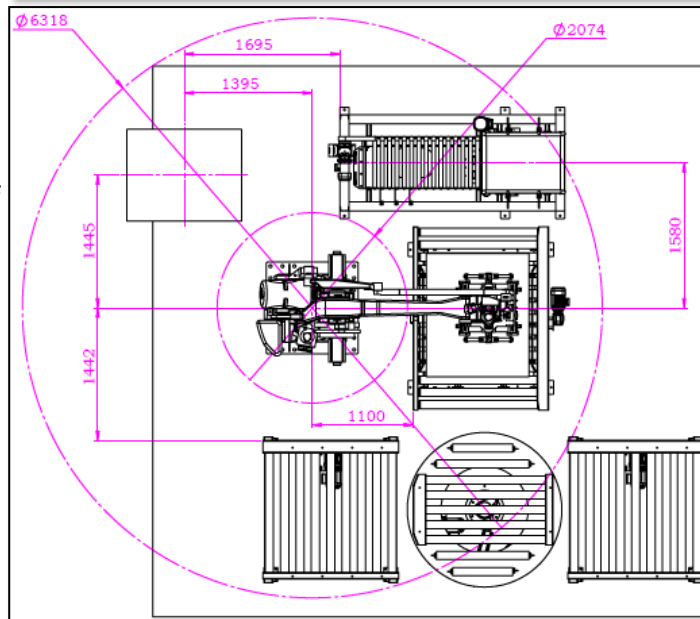
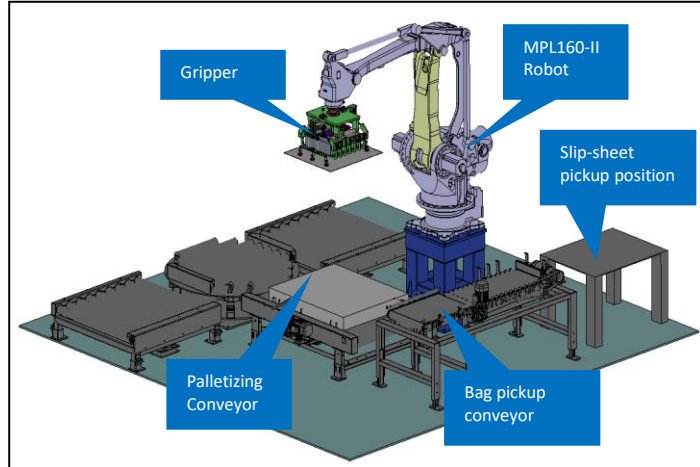

Objective of Robotics & Automation:

- To increase production volume
- To achieve uniform quality in placing bag
- To maintain single output line for different variants
- To reduce manual work
- To do complete line automation of Ceramic powder material handling

Process Description:

- Robot will pick the slip sheet first using Vacuum suction cup & place the slip sheet on the pallet.
- Bag from infeed will be centrally aligned in conveyor & input conveyor will stop when the bag presence sensor in the conveyor is ON.
- Robot pick the bag & place it as per the pattern sequence generated using pallet solver.
- If any error occurs or any quality issue in bag, robot will move to reject station & drop the bag in reject conveyor & continue palletizing from next bag.

Models Variants:

- Bag : 05 models
- Pallet : 03 variant
- Bag weight : 25 max.
- Slip sheet : 03 variant.

Cycle time : 450 bags/hr

Key Issue :

- There was issues in centering of bag in infeed .
- Inconsistent bags from infeed caused wrong placing of bags.

