

Segment: Non-Automobile Industry

Application: Handling System

Organization: Yaskawa India Pvt.Ltd.

Description:

Robotic Handling System for Non-Automobile Industries - The system synchronously places carton box on Refrigerators in a running conveyor.

Objective: Automated solution for placing carton uniformly on refrigerator to improve quality, eliminate human error and reduce manual work.

System Overview:

Stacking of carton box is done at input Slider through fork lift. Input Slider have Pneumatic carton sizing adjustment system which adjusts the clamping of cartons as per the model. Robot gripper consists of retractable Gripper Mechanism controlled through Robotic servo motor. Robot picks the carton using Vacuum Ejector & Opens the carton with servo controlled folding arm. Conveyor tracking function is used in the system to achieve best cycle time by synchronised loading of carton box on refrigerator in a running conveyor.

Scope of supply:

- Robot : MH180
- Controller : DX200
- Robot option function: Conveyor synchronised function
- PLC: Mitsubishi Q-Series .
- Gripper (Servo & Vacuum System)
- Safety Fence & Safety Door
- PLC panel & Operational Panel
- Variants Proved: 16

Application Layout:

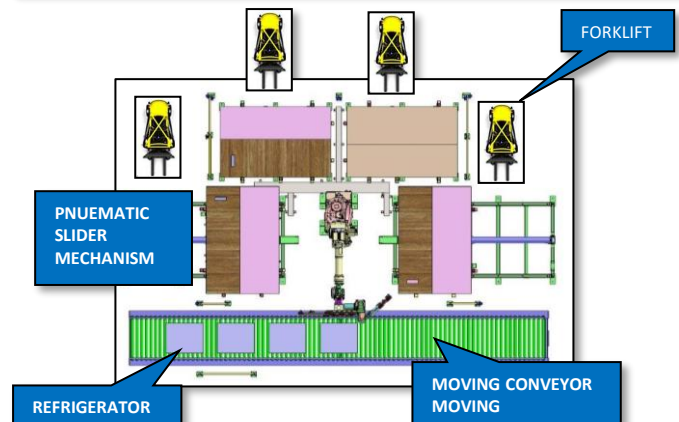
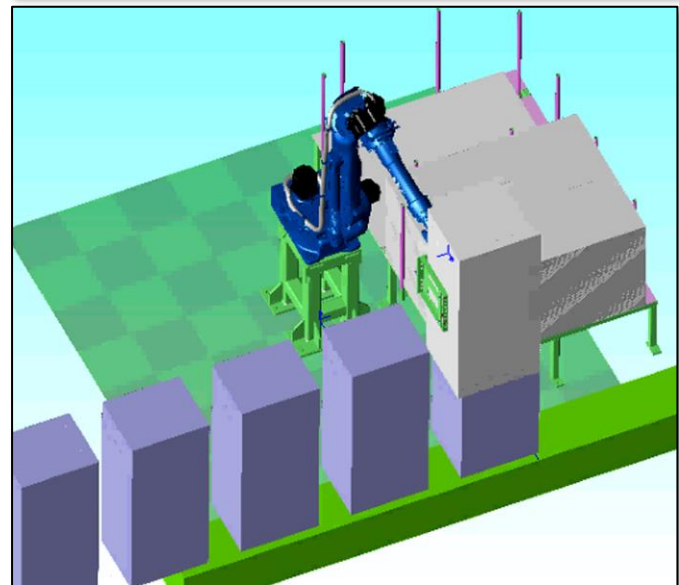
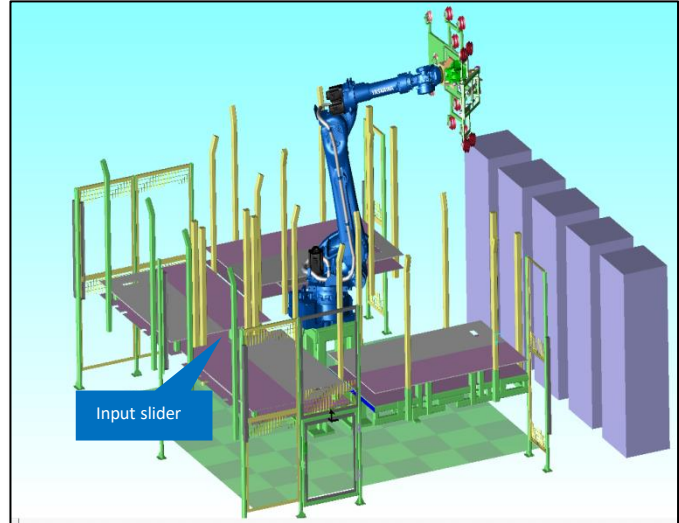

Objective of Robotics & Automation:

- To increase production volume
- To achieve uniform quality
- To maintain single output line for different variants
- To reduce manual work
- To do complete line automation of refrigerator assembly

Process Description:

- Carton box placed at input station assembly by fork lift
- Carton box locked by pneumatic cylinder
- Robot picks up carton box and opens through gripper
- Carton box placed on refrigerator by robot.
(refrigerator moved to location by conveyor)

Gripper Specification:

S.NO.	DESCRIPTION	SPECIFICATION
1	SERVO MOTOR	1.3KW
2	SERVO MOTOR OUTPUT TORQUE	8.34 NM
3	GEAR BOX RATIO	30
4	SPROCKET RATIO	30/17
5	TORQUE AT GEAR BOX OT	250.2 NM
6	TORQUE AT MAIN SHAFT	441 NM
7	VACCUM PAD DIAMETER	125 MM
8	VACCUM EJECTOR	1 PAD WITH 1

Success points:

- First time in India to place refrigerator carton box on running conveyor with robot.
- For all variants of refrigerator carton box implemented in one cell design.
- Conveyor tracking function successfully implemented with carton box placing.

Key Issue:

- Cycle time not achieved(target-12.5/actual 13.5)Sec.

Process Detail:

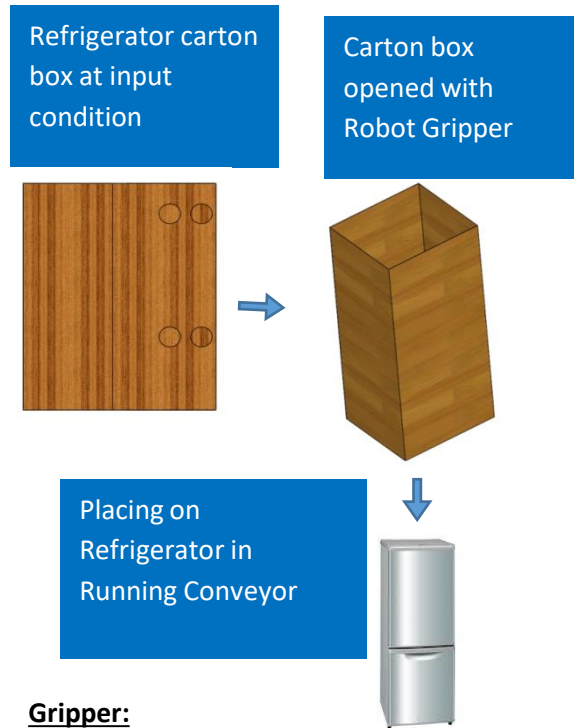

Gripper:

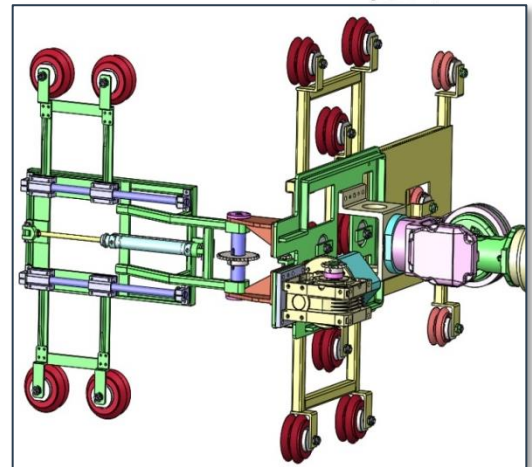

Pneumatic Input Slider:

